



Arched windows over looking Madison Avenue provide a striking back drop to the 88 position trading and brokerage floor of Baring Securities.

## The Customer Challenge

British-based Baring Securities has deep roots in America, having arranged the financing for the United States' purchase of Louisiana in 1803. With current growth propelled by their expertise in foreign markets, Baring needed to nearly double the trading and brokerage desks at their headquarters on Madison Avenue in New York. With limited floor area, it was especially important to use the layout and desk design to maximize space utilization. A diverse range of equipment and technology requirements demanded a highly flexible desk structure.

Baring expected continuing growth, which placed a premium on the ability to reconfigure desks easily.

## The Synthesis Solution

Working closely with Baring's Craig Duffy, Director of Administration, and John Sutherland, Vice President, Information Technology, the Synthesis team was able to develop a desk design that would accommodate the needs of both brokers and traders. The fully modular desks are attached and aligned to each other with a series of concealed cam locks; any single desk is interchangeable with any other desk on the floor providing unlimited reconfigurability.

Commenting on the client's requirement for a universal desk to meet the requirements of both traders and brokers, Synthesis designer Ira Saltz noted some of the specially designed components developed for Baring. "We were able to create a housing for either trader's turrets or broker's telephones in a single, multi-function enclosure. And with desk space at a premium, the top of the modular enclosure functions as either a monitor support or, with the insertion of wire dividers, a vertical paper organizer."

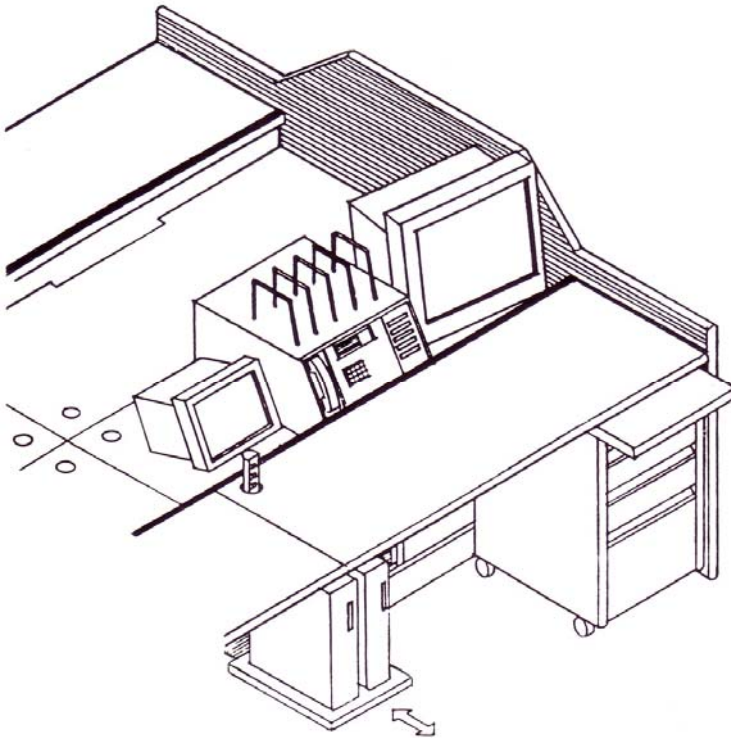

**An initial perspective drawing indicates design features of Baring's desk and is the basis for the detailed component drawings produced on our factory's CAD/CAM system.**

Each position also has a concealed reference shelf which slides out for additional desk top working space, and a mobile pedestal on casters. The pedestal design incorporates the same half-round bumper molding used to finish and protect the front edge of the desk. Cantilevered desktops provide a work surface with no interruptions between positions, and, behind removable sliding doors, the cable management area houses CPUs on a pull-out shelf supported by heavy duty extension slides. A retractable power module is located at each position, and a flexible cable management gasket that runs along the back edge of each desk top allows wires to pass from the desk top to the equipment well.

In order to maintain production control and the shortest lead times in the industry, all major elements of the Synthesis desk are manufactured "under one roof" at our technologically advanced factory. Two weeks prior to shipment, Craig Duffy visited the plant to inspect a completed desk and discuss final details. After his approval, all 88 desks were pre-assembled for final inspection prior to shipment.

For additional information please call **Datamation Systems:**  
(201) 329-7200 or (212) 732-3824 FAX (201) 329-7272

Datamation Systems, Inc., 125 Louis Street, South Hackensack, NJ 07606-1733  
email: [Datamation@pobox.com](mailto:Datamation@pobox.com) web: [www.technicalfurniture.pc-security.com](http://www.technicalfurniture.pc-security.com)

